

FT2000C

Track-Mounted Cone Crushing Plant



Kodiak® K200+Crusher

- High efficiency roller bearing design
- Remote Close Side Setting (CSS) adjustment
- Patented mechanical "crusher duty" cone brake
- Patented liner retention assembly
- Bronze field replaceable V-seat liners
- Permanently precision balanced
- Protected internal counter weights
- Baseframe tub liners field replaceable 400BHN
- Cold-climate oil recirculation
- Manganese liners (select from list of interchangeable liners)
- Crusher tools
- Operation and maintenance manuals
- Crusher feed hopper

Chassis

- I-beam/box frame design balanced for zero cribbing
- Components fold for transport
- Grease lines for easy maintenance

Heavy Duty Belt Feeder

- 48" feed conveyor
- Heavy duty grade 1 belting
- Loading hopper with 6 cubic yard capacity

Under Crusher Conveyor

- 36" under crusher conveyor
- Grade II, 330 3 ply belting
- Fully skirted, 45 degree troughing rollers
- Tail section lowers for maintenance access

Power Unit

- Cummins QSL9 Tier 4 Final rated @ 350hp/260kW
- 200gal/757L fuel tank
- Baghouse air filtration system

Controls

- Automatic feed regulation into the cone
- Engine overload protection
- Diagnostics with historical storage
- Color display with keypad
- 24V controls
- Wireless remote (track drive/feeder)
- Bowl float detection
- Dust suppression

Options:

- Hydraulic cone brake
- Return Conveyor
- Extended under-crusher conveyor with hydraulic fold
- CAT C9 Tier 3 rated @ 325hp/240kW
- Cold weather kit (optional)

Physical/Operating Characteristics

Dimension	Standard	Metric
Operating Length	46'-9"	14.2 m
Operating Height	15'-3 1/2"	4.7 m
Travel Height	11'-6"	3.5 m
Travel Width	9'-4 1/4"	2.9 m
Feed Height	10'-8"	3.3 m
Max Feed Size Up To	9.5"	241 mm
Unit Weight (standard)*	80,000 LBS	36,290 kg

Travel Mode

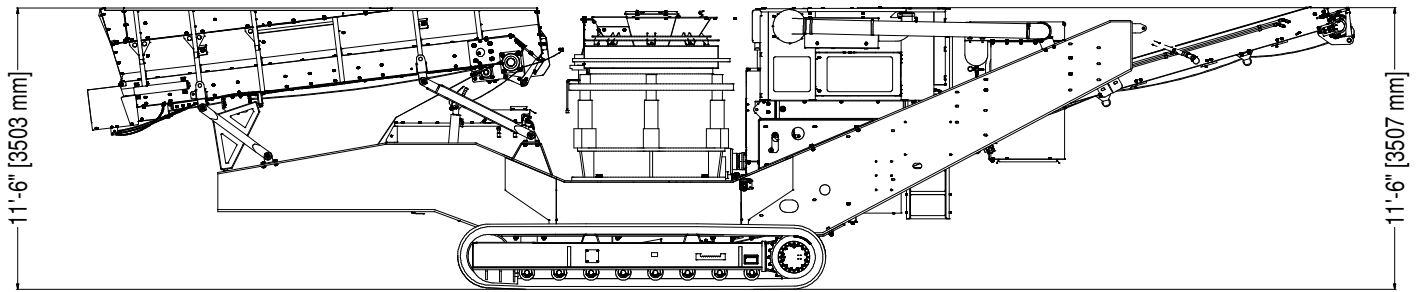

Operation Mode

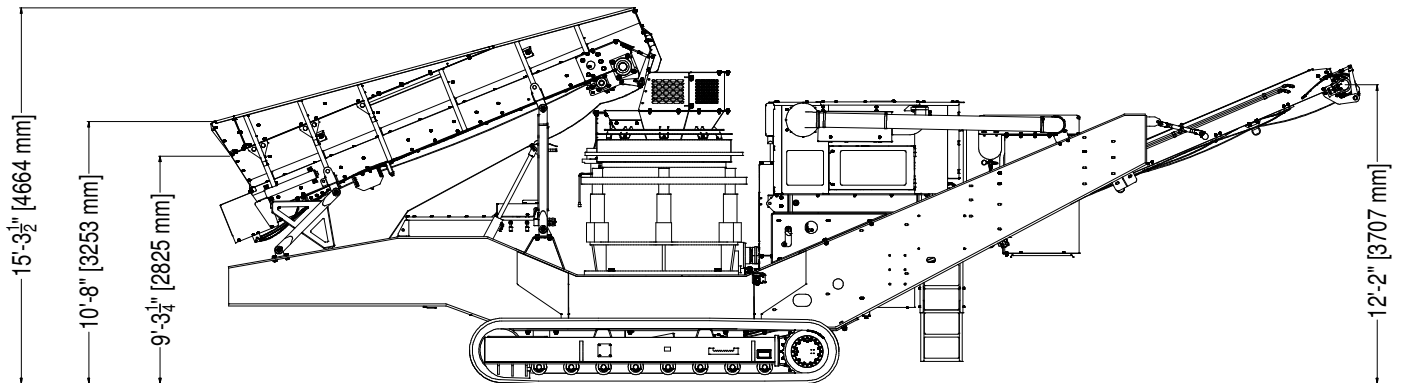

Johnson Crushers International, Inc.
 86470 Franklin Blvd.,
 Eugene, OR 97405
 1 (800) 314-4645
 mail@jcieug.com
 www.kpijci.com

NOTE: CONSULT FACTORY FOR EXACT DIMENSIONS, specifications are subject to change without notice.

Because Kolberg-Pioneer, Inc., Johnson Crushers International, Inc. and Astec Mobile Screens, Inc. may use in their catalog and literature, field photographs of their products which may have been modified by the owners, products furnished by Kolberg-Pioneer, Inc., Johnson Crushers International, Inc. and Astec Mobile Screens, Inc. do not warrant or represent that their products meet any federal, state, or local statutes, codes, ordinances, rules, standards or other regulations, including OSHA and MSHA, covering safety, pollution, electrical wiring, etc. Compliance with these statutes and regulations is the responsibility of the user and will be dependent upon the area and the use to which the product is put by the user. In some photographs, guards may have been removed for illustrative purposes only. This equipment should not be operated without all guards attached in their normal position. Placement of guards and other safety equipment is often dependent upon the area and how the product is used. A safety study should be made by the user of the application, and, if required additional guards, warning signs and other safety devices should be installed by the user, wherever appropriate before operating the products.